



Because privacy matters!™

ISO 9001:2015 CERTIFIED COMPANY ISO 14001:2015 CERTIFIED COMPANY



# Kubebooth Technical Data Sheet KTeam 8

Note: This is only a sample Size. Various Sizes exists to fit your needs

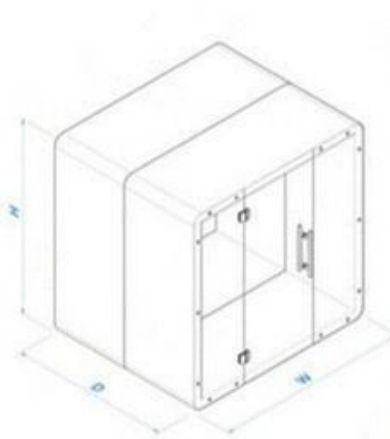

**Size**  
Overall - W: 88" - D: 145" - H: 88"  
Inside - W: 80" - D: 144" - H: 80"

**Weight**  
3000 lbs/1361 kg

**Glass** 10mm clear tempered  
Ceramic painted borders  
Door - H: 88" x W: 36"  
Rear Panels - H: 88" x W: 44"  
Front Side Panels - H: 88" x W: 26"

**Reversible Door**  
Fully interchangeable left or right opening

**Worktop** White or Black laminate wood worktop D Shape

**Felt**  
Interior sound absorption panels  
60% recyclable

**Options**  
Seismic bracing  
One touch LCD control panel  
LCD TV mount bracing  
White glass board - W: 34" x L: 30"  
Personalized company branding  
Ethernet ports  
Bluetooth speaker  
Frosted film glass  
External fire extinguisher unit  
Smart lock  
Occupancy lights

**Acoustics**  
NIC rating of 36 dB certified  
Noise cancellation technology

**Air Exchange**  
100 complete air changes per hour

**Data Center**  
1 USB A port, 1 USB C port 2  
Simplex outlets Motion detector  
(controls light & fan)

**Mobility Kit**  
Includes casters with fasteners

**Light**  
12V LED light bar with magnet  
570mm/pcs super light bar, 3500K,  
12VDC

**Sprinkler**  
Pre-engineered knockout hole for 3rd party sprinkler installation

**Power Cord**  
10ft cord 120V/15Amp

**UL Certified**  
The electric connections in this pod are UL certified for safety and reliability

**Wall Construction**  
Galvanized steel frames  
Sound insulation in all cavities

**Finishes**  
D-pull handle  
TFL surface  
CARB certified  
(zero/low formaldehyde emissions)  
Aluminum hardware painted

**Carpet**  
Shaw Commercial Philadelphia Ayers Hall II or equal  
Solution dyed polypropylene 28 oz, 10 gauge  
GreenGuard certified GLP8472  
<450 NBS smoke

**Floor Ceiling**  
Substructure-rated MDF on unitized steel base.

**IMPORTANT BUILDING / SPRINKLER NOTE**

All units include a sprinkler "knockout" provision. Final requirements vary by jurisdiction and building conditions, customers must confirm the required approach with their building inspector / AHJ (Authority Having Jurisdiction) before installation.

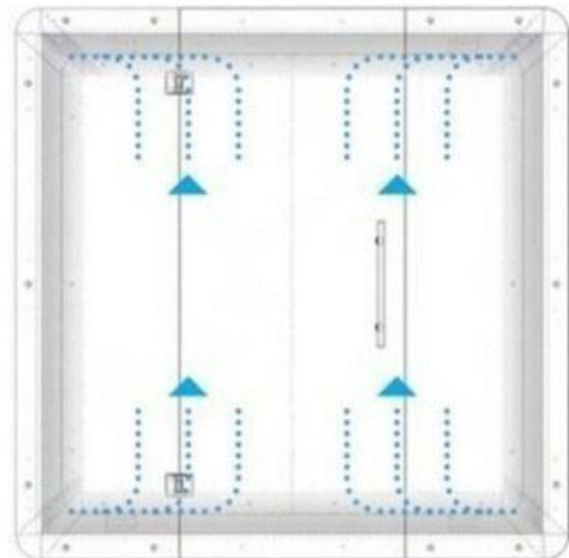

\*Air Flow Diagram

