

Kubebooth Technical Data Sheet - Ki+

Because Privacy Matters



Made In Canada

Easy to Install

Extendable

Moveable

Plug & Play

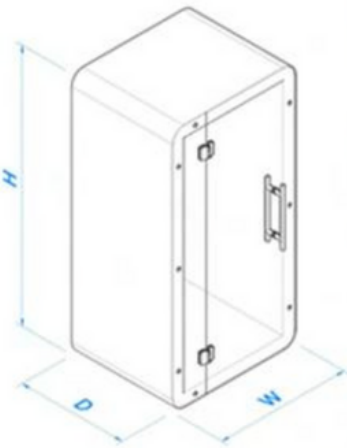

Size

Overall - W: 58" - D: 37.5" - H: 88"
 Inside - W: 50" - D: 36" - H: 80"

Weight

950 lbs/431 kg

Glass

10mm clear tempered
 Ceramic painted borders
 Door - H: 88" x W: 32"
 Front Side Panel - H: 88" x W: 26"

Power Cord

100" cord 120V/15Amp

Acoustics

NIC rating of 36 dB certified
 Noise cancellation technology

Air Exchange

100 complete air changes per hour

Data Center

UL approved
 2 USB ports
 2 Simplex outlets
 Motion detector (controls light & fan)

Rear Finish

Laminated Wood Finish

Mobility Kit

Includes casters with fasteners

Light

12V LED light bar with magnet
 570mm/pcs super light bar, 3500K,
 12VDC

Sprinkler

Pre-engineered knockout hole for 3rd party sprinkler installation

Wall Construction

Galvanized steel frames
 Sound insulation in all cavities

Finishes

D-pull handle
 TFL surface
 CARB certified (zero/low formaldehyde emissions)
 Aluminum hardware painted

Carpet

Shaw Commercial Philadelphia Ayers Hall II or equal
 Solution dyed polypropylene 28 oz, 10 gauge
 GreenGuard certified GLP8472 <450 NBS smoke

Reversible Door

Fully interchangeable left or right opening

Floor Ceiling

Substructure rated MDF on unitized steel base

Felt

Interior sound absorption panels
 60% recyclable

Options

Seismic bracing
 LCD TV mount bracing
 White glass board - W: 34" x L: 30"
 Personalized company branding
 Ethernet ports
 Bluetooth speaker



*Air Flow Diagram