

Kubebooth Technical Data Sheet - KADA

Because Privacy Matters



Made In Canada

Easy to Install

Extendable

Plug & Play

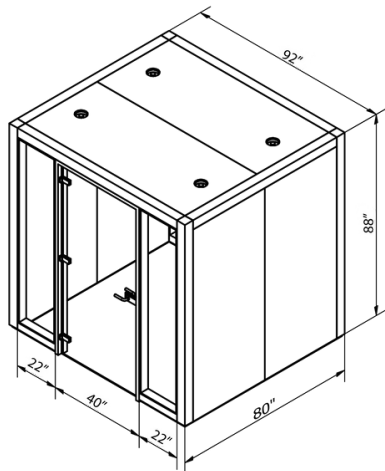

Size

Overall - W: 92" - D: 80" - H: 88"
 Inside - W: 84" - D: 72" - H: 84"
 Door clearance - 35"

Weight

1600 lbs/726 kg

Glass

Door - 10mm clear tempered
 Side/back - Double glass clear tempered
 Aluminium framed glass
 Door - H: 88" x W: 40"
 Rear Panel - H: 88" x W: 42"
 Front Side Panel - H: 88" x W: 22"

Acoustics

NIC rating of 36 dB certified
 Noise cancellation technology

Air Exchange

100 complete air changes per hour

Data Center

UL approved
 2 USB ports
 2 Simplex outlets
 Motion detector (controls light & fan)

Light

12V LED light bar with magnet
 570mm/pcs super light bar, 3500K, 12VDC

Sprinkler

Pre-engineered knockout hole for 3rd party sprinkler installation

Power Cord

100" cord 120V/15Amp

Wall Construction

Galvanized steel frames
 Sound insulation in all cavities

Finishes

Lever handle
 TFL surface
 CARB certified (zero/low formaldehyde emissions)
 Aluminum hardware painted or anodized

Reversible Door

Fully interchangeable left or right opening

Felt

Interior sound absorption panels
 60% recyclable

Ceiling

Felt

Options

Pull handle + Door lever
 Automatic accessible door
 LCD TV mount bracing
 Magnetic white glass board - W: 34" x L: 30"
 Personalized company branding
 Ethernet ports
 Bluetooth speaker

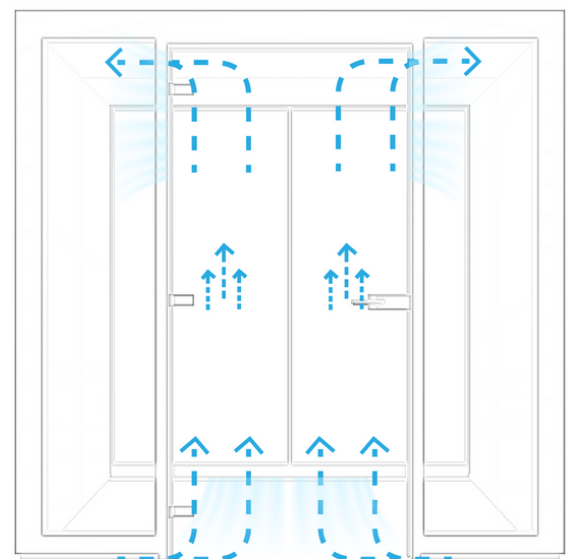

*Air Flow Diagram