

KUBEBOOTH TECHNICAL DATA SHEET - Kme

Because Privacy Matters



Made In Canada

Easy to Install

Extendable

Moveable

Plug & Play

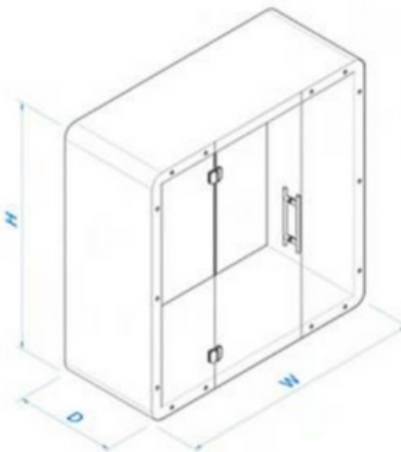

Size

Overall - W: 88" - D: 37" - H: 88"
Inside - W: 80" - D: 36" - H: 80"

Weight

1200 lbs/544 kg

Glass

10mm clear tempered
Ceramic painted borders
Door - H: 88" x W: 36"
Rear Panel - H: 88" x W: 44"
Front Side Panels - H: 88" x W: 26"

Power Cord

100" cord 120V/15Amp

Acoustics

NIC rating of 36 dB certified
Noise cancellation technology

Air Exchange

100 complete air changes per hour

Data Center

UL approved
2 USB ports
2 Simplex outlets
Motion detector (controls light & fan)

Mobility Kit

Includes casters with fasteners

Light

12V LED light bar with magnet
570mm/pcs super light bar, 3500K,
12VDC

Sprinkler

Pre-engineered knockout hole for 3rd
party sprinkler installation

Wall Construction

Galvanized steel frames
Sound insulation in all cavities

Finishes

D-pull handle
TFL surface
CARB certified (zero/low formaldehyde
emissions)
Aluminum hardware painted

Carpet

Shaw Commercial Philadelphia Ayers Hall
II or equal
Solution dyed polypropylene 28 oz, 10
gauge
GreenGuard certified GLP8472 <450 NBS
smoke

Reversible Door

Fully interchangeable left or right opening

Floor Ceiling

Substructure rated MDF on unitized steel base

Felt

Interior sound absorption panels
60% recyclable

Options

Seismic bracing
LCD TV mount bracing
White glass board - W: 34" x L: 30"
Personalized company branding
Ethernet ports
Bluetooth speaker

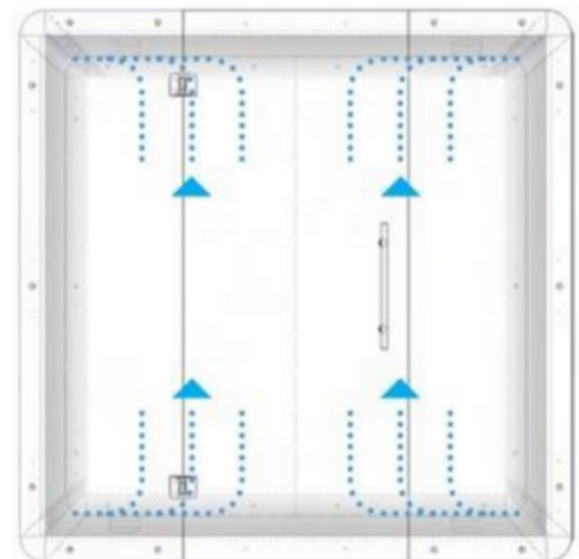

*Air Flow Diagram